

General Crossmember Installation Directions

1. Place frame on axle stands or table and scribe a mark at the original axle centerline. Try to get this measurement as close as possible.
2. Remove front suspension and steering. On some vehicles the original crossmember need not be removed. On many Chevy's and Mopar's the crossmember may be left in it's stock location. The Fords however, will need substantial trimming off the bottom of the crossmember or complete removal. If you remove the crossmember completely always weld bars across front of frame above & below to keep the frame rails from moving. After the original crossmember is removed you can trial fit the IFS crossmember.
3. It is important that you position the frame front to rear at the angle it will be when the car is finished. Decide where the front of the frame will be to the ground and also the rear of the frame to the ground. This will be the rake of the frame (downward angle).
4. What can happen if you for instance place the frame on a table or put it up on axle stands and have the frame, let's say "level" and you then put the crossmember in straight up vertical – you think everything is fine. It may be fine, however, if you now assemble the car and put your small tires in front and big ones in back, the frame is now on a rake and the IFS crossmember instead of straight up and down is now tipping forward – this is not good. Repeat NOT GOOD! It must be vertical or even leaned back a little, as much as 2° that's perfectly OK, but never tipping forward. If when the car is finished and you find that you have installed the crossmember improperly and it has a slight forward "tilt" the drivability of the car will be affected and be very sensitive to steering and will be ill-handling. If it is tipping even slightly forward and you adjust the castor and camber to make up for it within specifications, it still won't be right. So be careful here.
5. When the crossmember is installed in the standard location the spindle centerline will be 1" above the bottom of the frame (fig. 1). If you find that your vehicle will be riding too low (after you determine your tire size diameter) you may want to space the frame up from the crossmember with a suitable fabricated spacer (fig. 2). This way of raising the car works only with the one-piece crossmember ('28-'34 Ford style) conversely, if you wish to lower the front of the frame more you may notch the crossmember (fig.3). Keep in mind however when you sink the frame deeper in the crossmember, you could have upper a-arm to fender clearance problems. The car can also be raised or lowered by the shock/spring adjustment approximately 1" up or down.
6. Our crossmembers are constructed in a manor that allows the upper a-arm to be positioned slightly to the rear of the crossmember centerline. There are two different sizes of the aluminum eccentric adjusters (fig.4); the thinner one to the front of the a-arm and the wider one to the rear of the a-arm accomplishes this set back. When the upper a-arm is moved back in this manor it will cause the spindle upright to lean back just enough to have a built in 2° to 3° caster (NOTE: Leaning back the entire crossmember in the chassis will also give you additional caster). Now by having the upper a-arm slightly to the rear we have also moved the wheel centerline to the rear approximately ¼" shortening the wheelbase by ¼", so we recommend sliding the entire crossmember centerline ¼" forward of the original axle centerline you marked as per instruction #1, so the wheelbase will be back to stock.

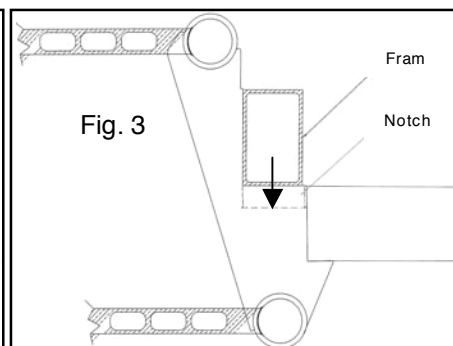
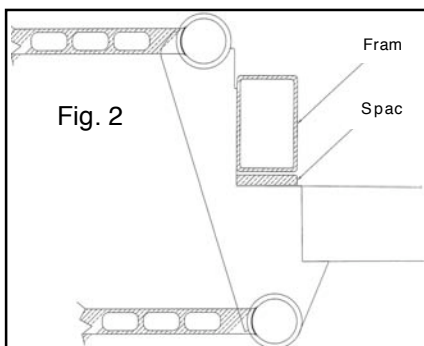
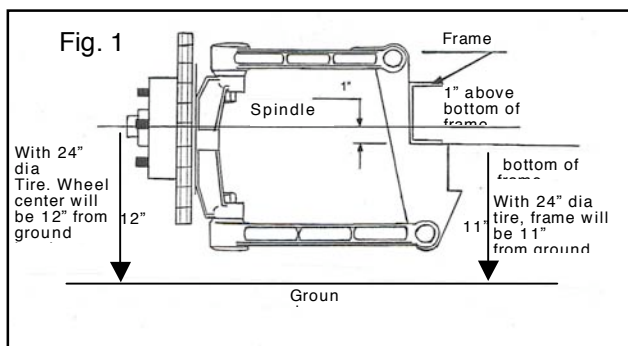

Example: 24" diameter tire = bottom of frame is 11" from ground level.

Set Screws must be in line with flats milled on the thru bolt (fig.5). That done, now tighten set screws on to flats – this allows the thru bolt when rotated to move the a-arm in or out to adjust camber ¼° negative to ¼° positive after adjustment in complete tighten the nyloc to 125 ft. lbs.

Narrow Eccentric Fig. 4 Wider Eccentric

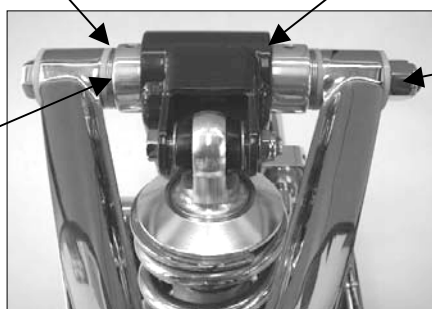

Flat spot on end of bolt thread is in line with flat spots milled on thru bolt (Fig. 5) to indicate where the flats are when the a-arm is assembled.

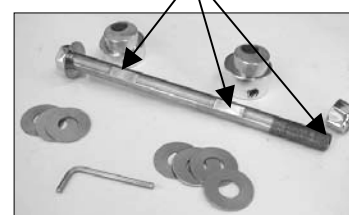

Fig. 5

← Forward